



(12) **United States Patent**  
**Kajiura et al.**

(10) **Patent No.:** **US 6,798,104 B2**  
(45) **Date of Patent:** **Sep. 28, 2004**

(54) **ROTARY ELECTRIC MACHINE FOR ELECTRIC VEHICLE**

(75) Inventors: **Hiroaki Kajiura**, Nagoya (JP);  
**Masahiro Seguchi**, Obu (JP)

(73) Assignee: **Denso Corporation**, Kariya (JP)

(\*) Notice: Subject to any disclaimer, the term of this patent is extended or adjusted under 35 U.S.C. 154(b) by 0 days.

(21) Appl. No.: **10/319,565**

(22) Filed: **Dec. 16, 2002**

(65) **Prior Publication Data**

US 2003/0090167 A1 May 15, 2003

**Related U.S. Application Data**

(62) Division of application No. 09/689,773, filed on Oct. 13, 2000, now Pat. No. 6,563,246.

(30) **Foreign Application Priority Data**

Oct. 14, 1999 (JP) ..... 11-292304  
May 1, 2000 (JP) ..... 2000-132044  
May 1, 2000 (JP) ..... 2000-132423  
Aug. 11, 2000 (JP) ..... 2000-243914

(51) **Int. Cl.<sup>7</sup>** ..... **H02K 19/00**

(52) **U.S. Cl.** ..... **310/162; 310/166**

(58) **Field of Search** ..... 319/162, 166,  
319/168, 112, 113, 114, 121, 156.53-156.57

(56) **References Cited**

**U.S. PATENT DOCUMENTS**

4,488,077 A \* 12/1984 Kovacs ..... 310/212

4,945,296 A \* 7/1990 Satake ..... 318/538  
5,144,180 A \* 9/1992 Satake et al. .... 310/212  
6,087,752 A \* 7/2000 Kim et al. .... 310/156.51  
6,147,428 A \* 11/2000 Takezawa et al. .... 310/156.57  
6,353,275 B1 \* 3/2002 Nishiyama et al. .... 310/156.53  
6,426,576 B1 \* 7/2002 Varenne ..... 310/156.09

**FOREIGN PATENT DOCUMENTS**

JP 7-59310 3/1995  
JP 7-143694 6/1995  
JP 9-294362 11/1997  
JP 10-201148 7/1998  
JP 11-89136 3/1999  
JP 11-89145 3/1999  
JP 11-98721 4/1999  
JP 11-136892 5/1999  
JP 11-252881 9/1999  
JP 11-275789 10/1999

\* cited by examiner

*Primary Examiner*—Thanh Lam

(74) *Attorney, Agent, or Firm*—Oliff & Berridge, PLC

(57) **ABSTRACT**

A rotary electric machine includes a stator core having a plurality of slots disposed at an inner periphery, an armature winding disposed in the slots and a rotor disposed inside the inner periphery of the stator. The rotor includes a first rotor portion and a second rotor portion, which are disposed magnetically in parallel with each other. The first rotor portion has a plurality of permanent-magnet poles, and a second rotor portion has a plurality of salient induction poles.

**6 Claims, 20 Drawing Sheets**

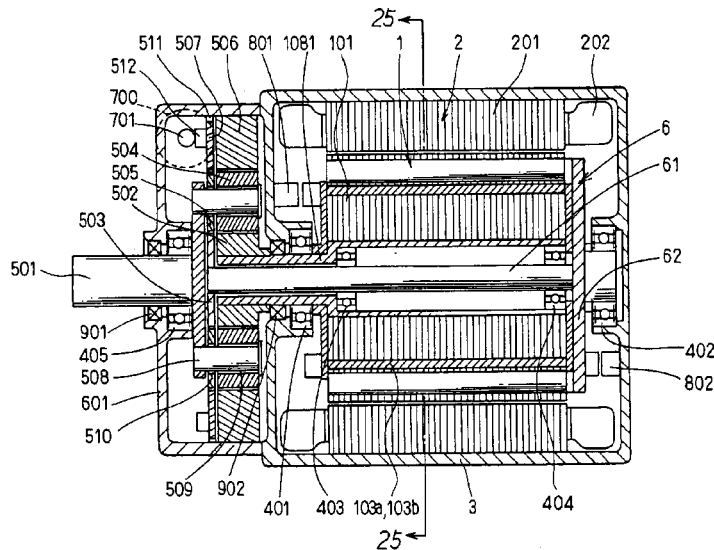

FIG. 1

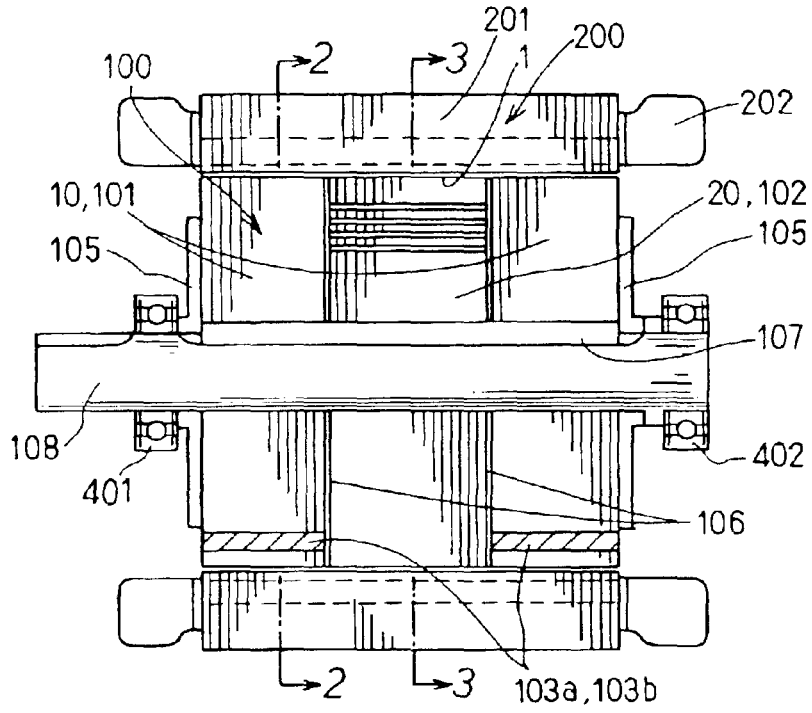

FIG. 2

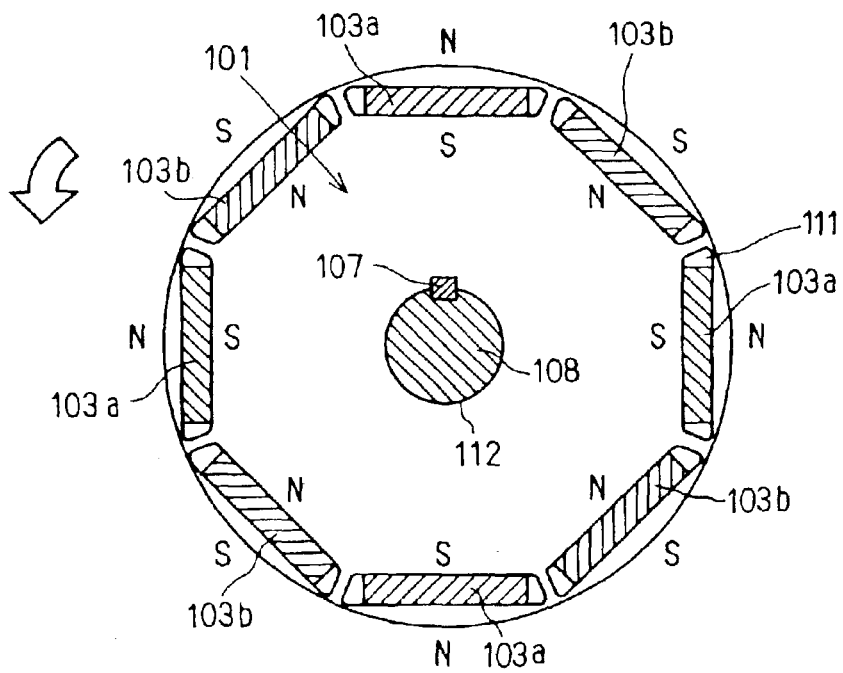

FIG. 3

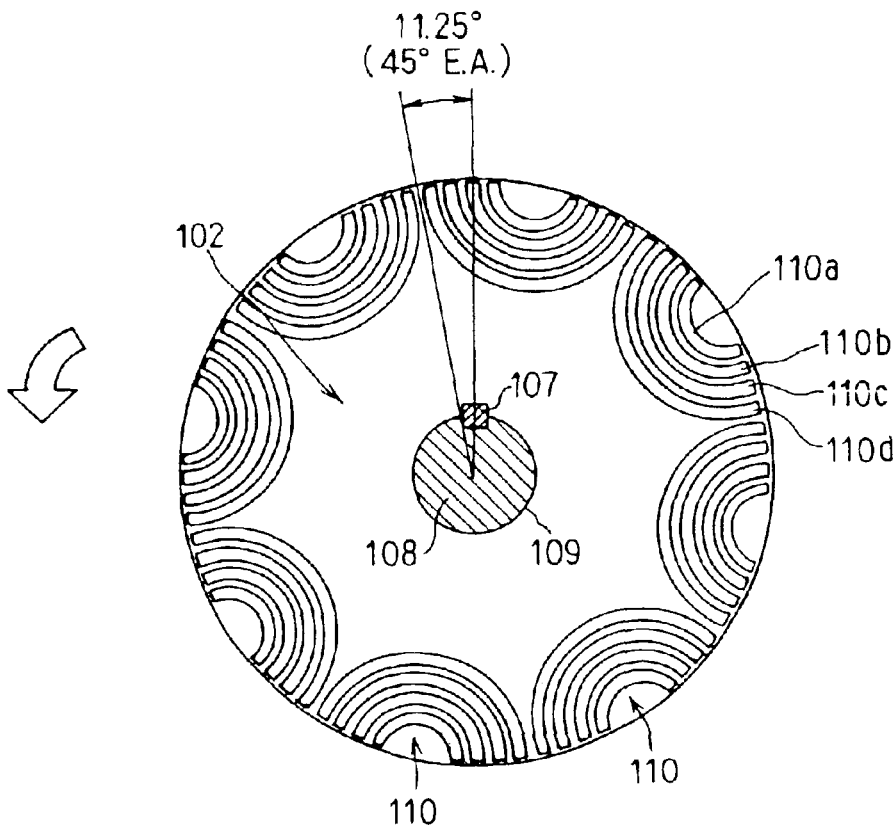

FIG. 4

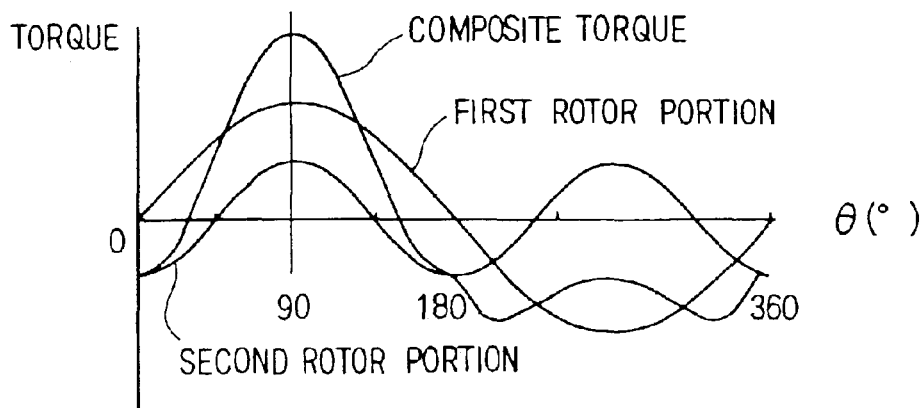

FIG. 5

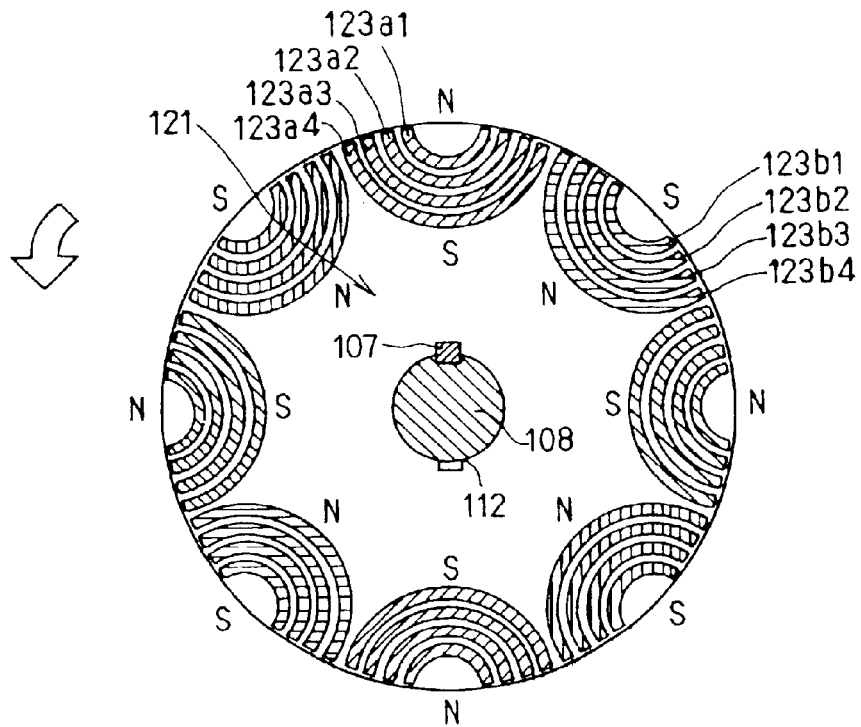

FIG. 6

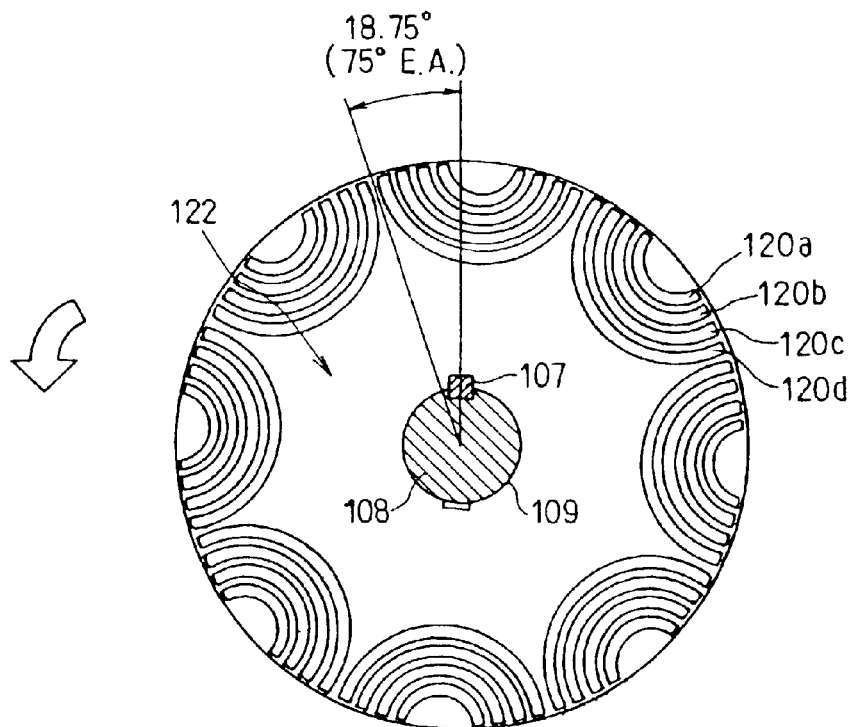

FIG. 7

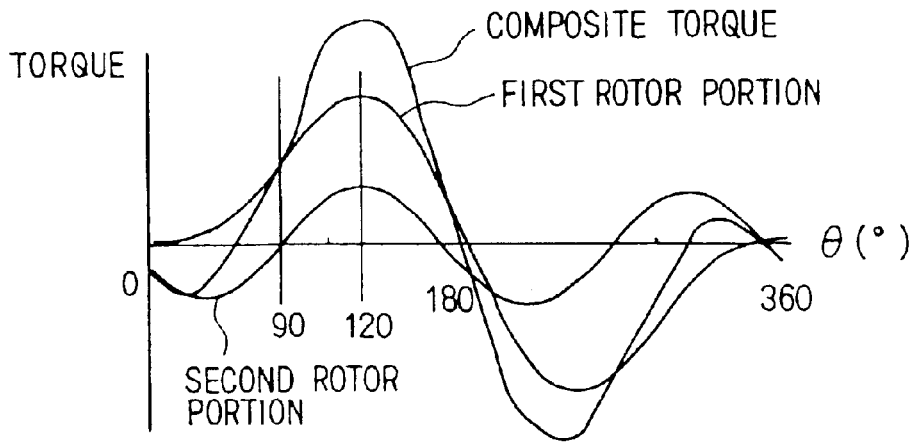

FIG. 8

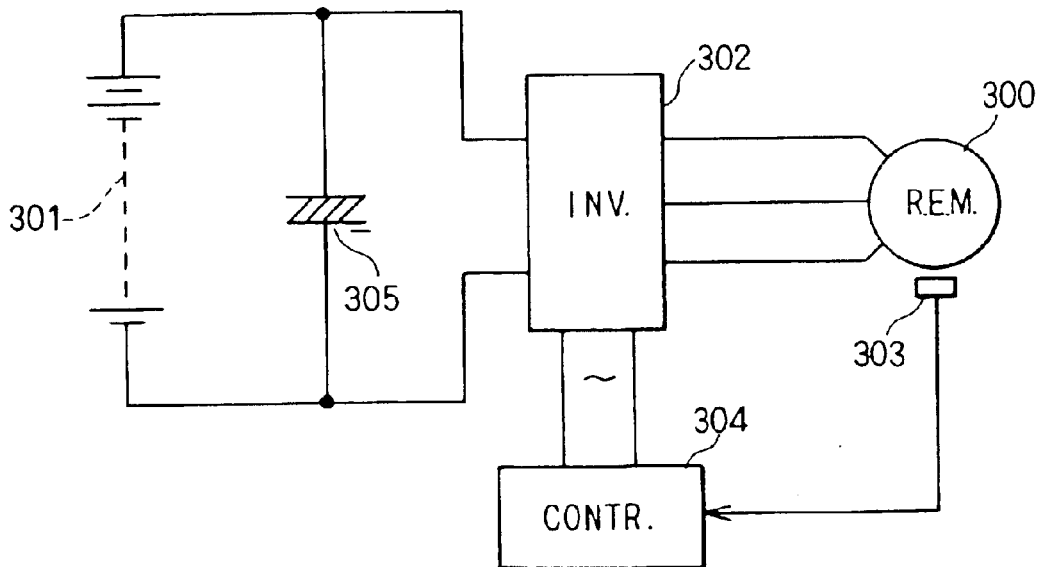



FIG. 10

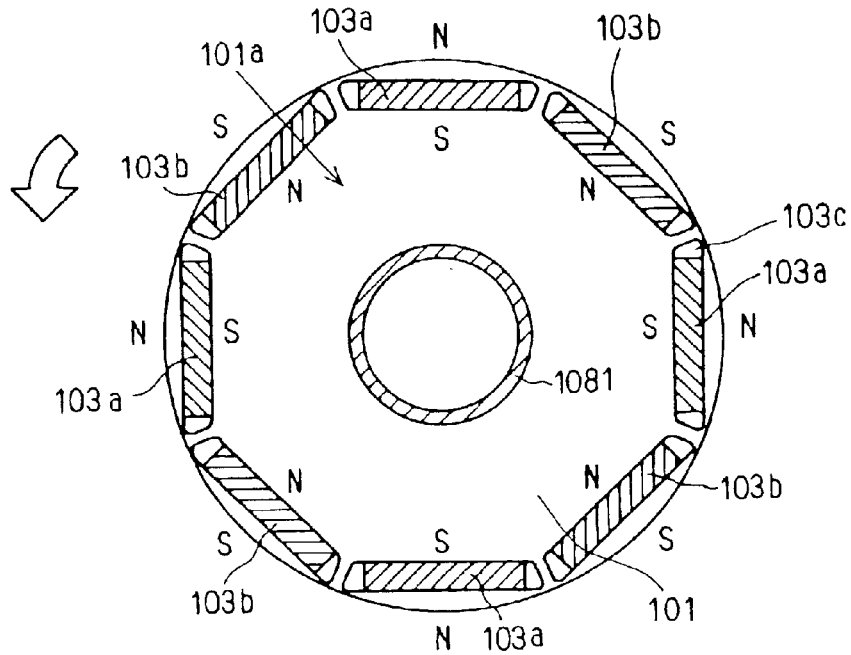
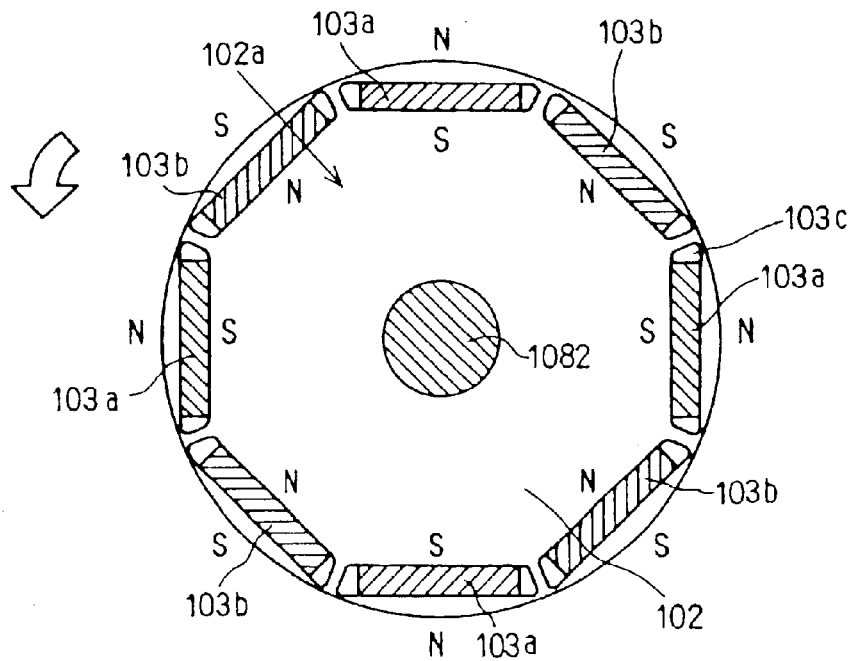
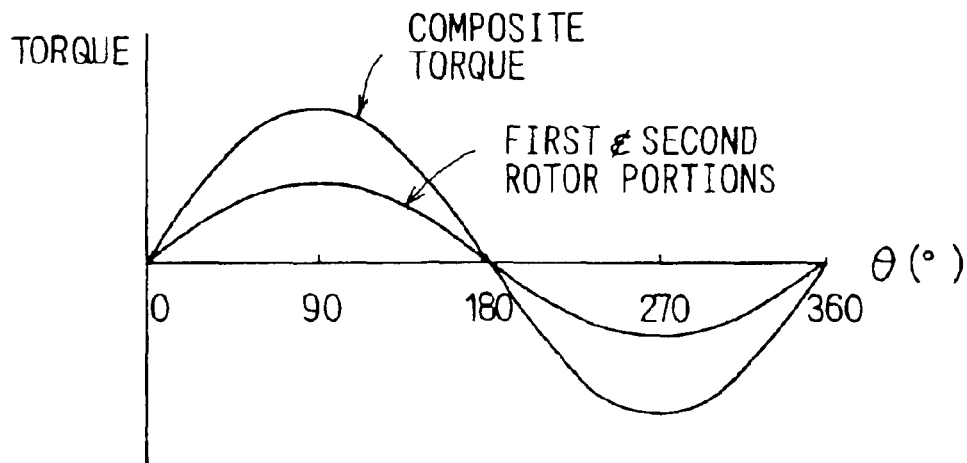

FIG. 11



# FIG. 12

PHASE DIFFERENCE 0°



# FIG. 13

PHASE DIFFERENCE 90°

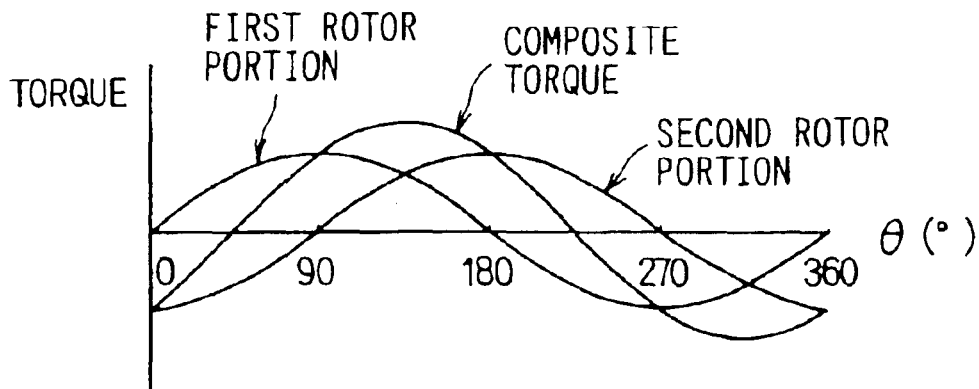

# FIG. 14

PHASE DIFFERENCE 180°

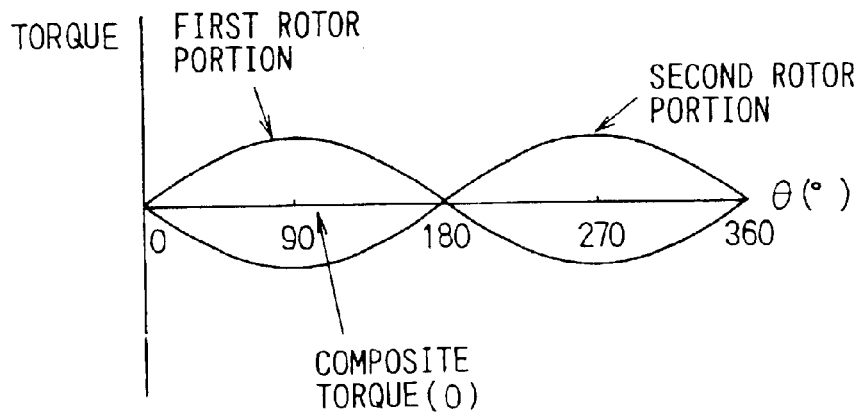

# FIG. 15

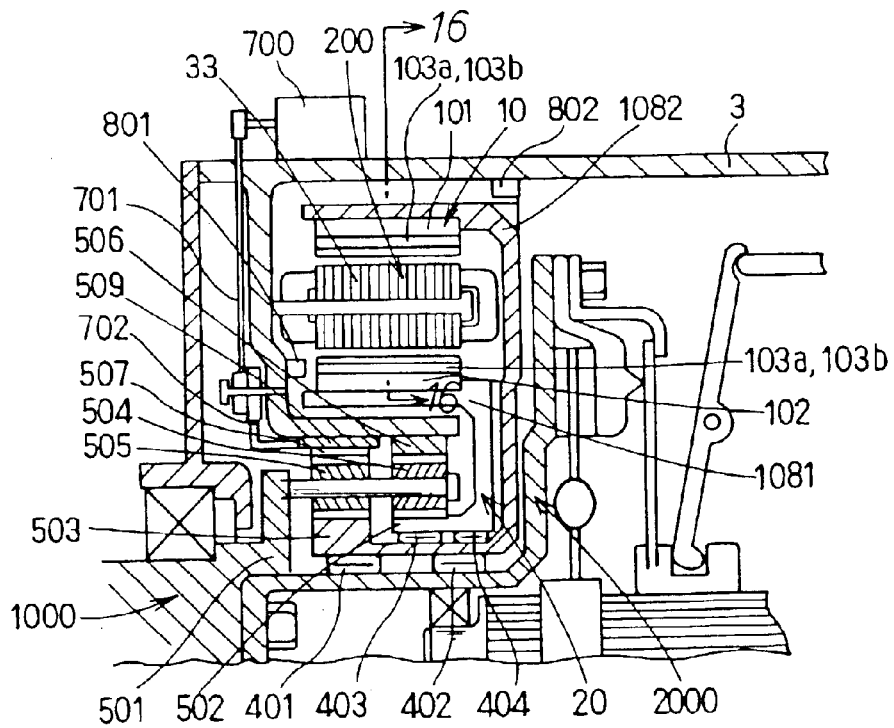

FIG. 16

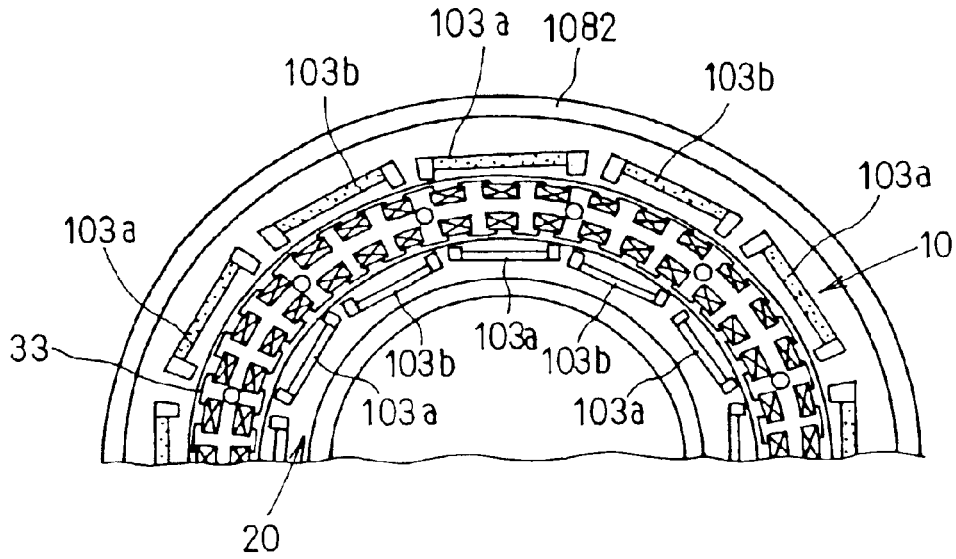

FIG. 17

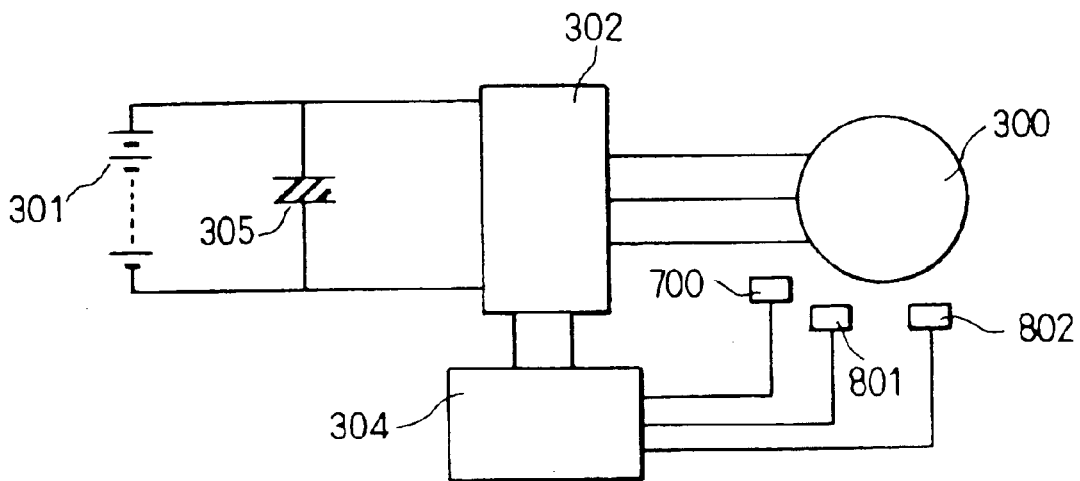

FIG. 18

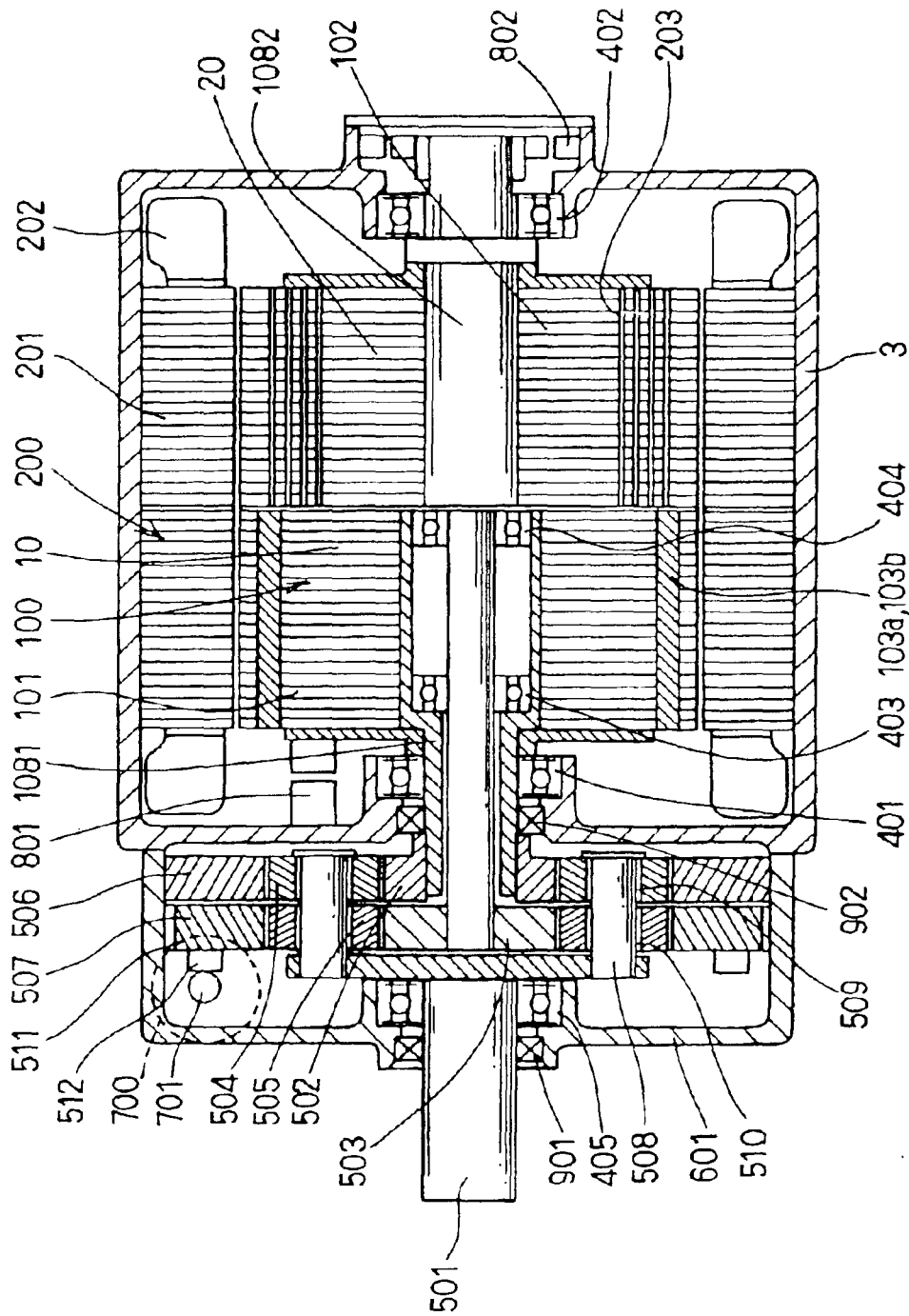

FIG. 19

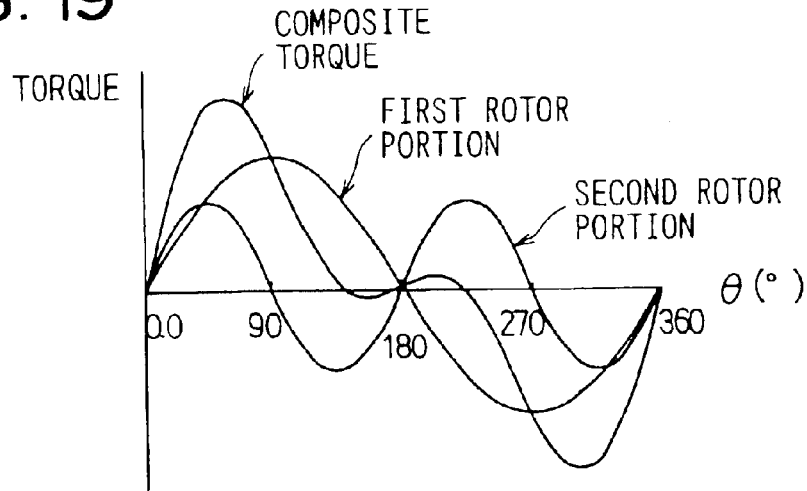

FIG. 20

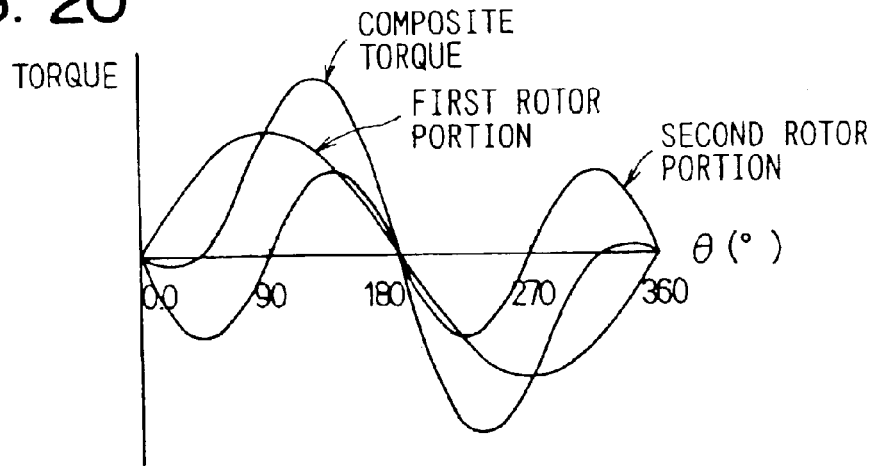

FIG. 21

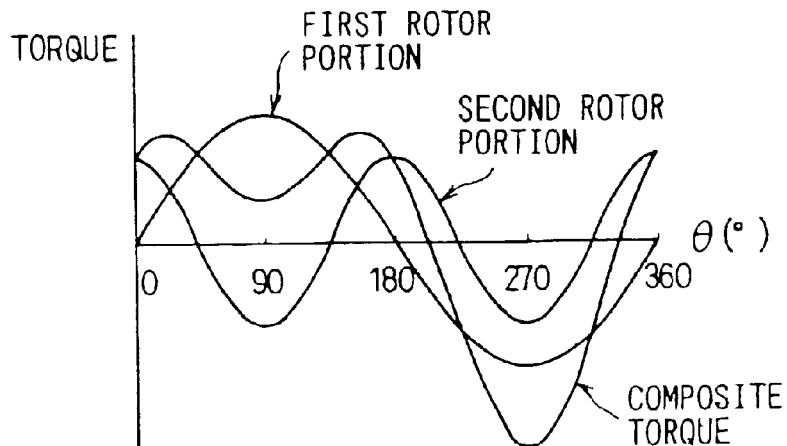

FIG. 22

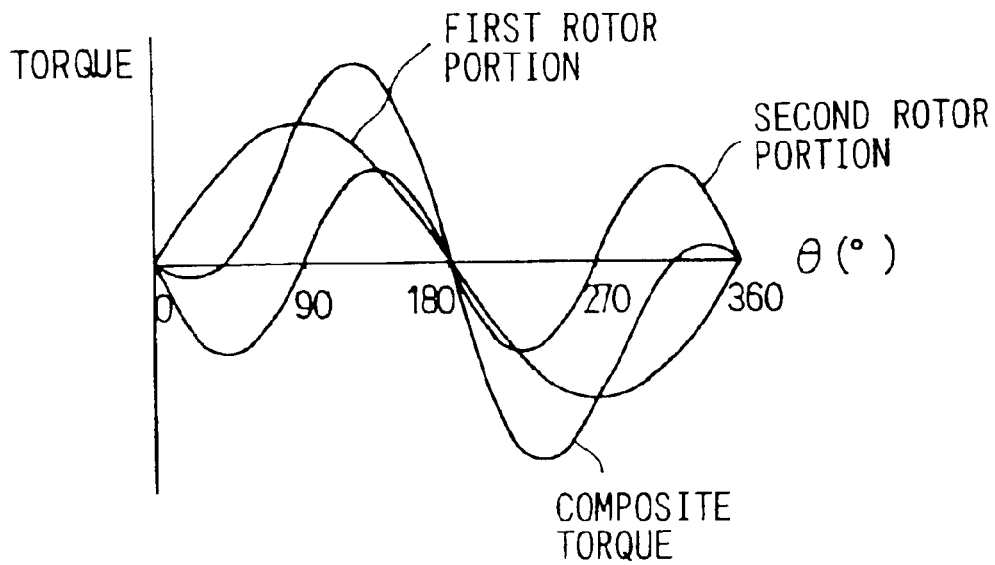

FIG. 23

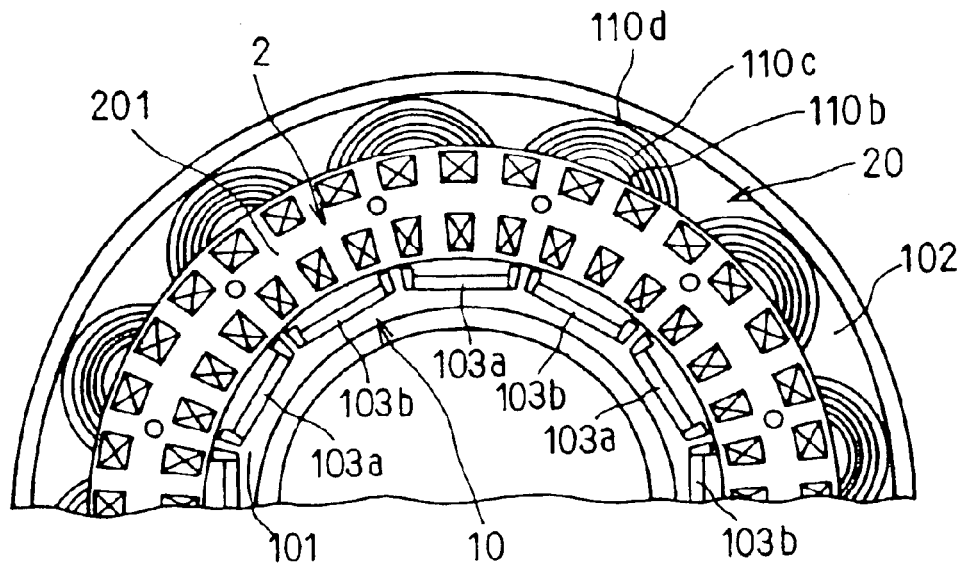



FIG. 25

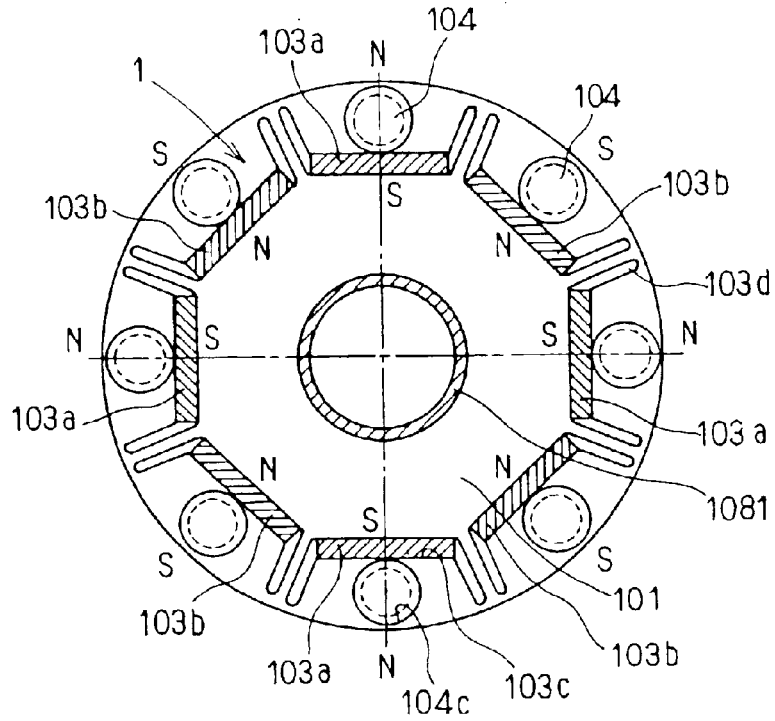

FIG. 26

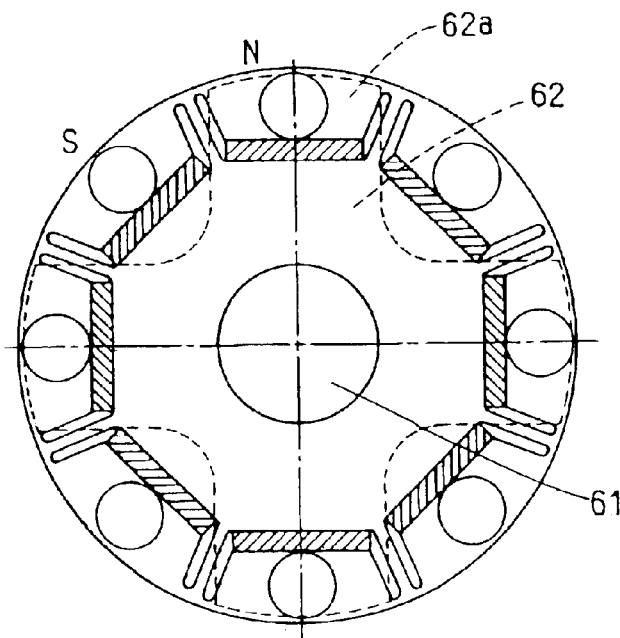

FIG. 27

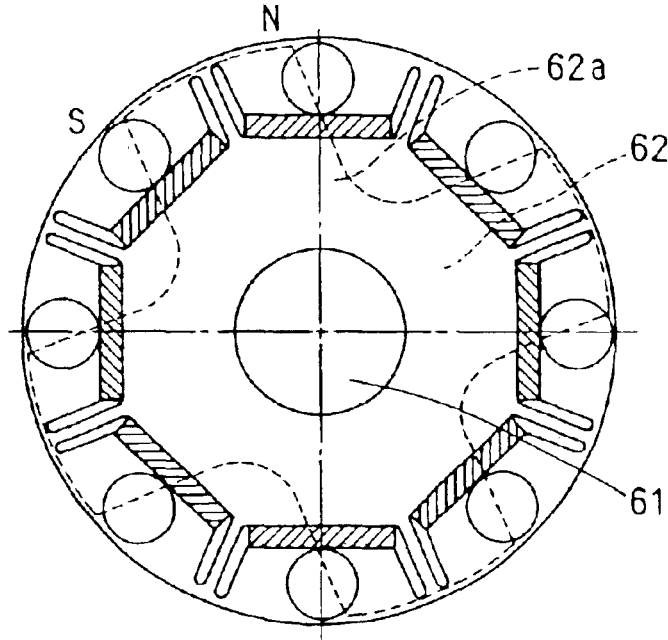

FIG. 28

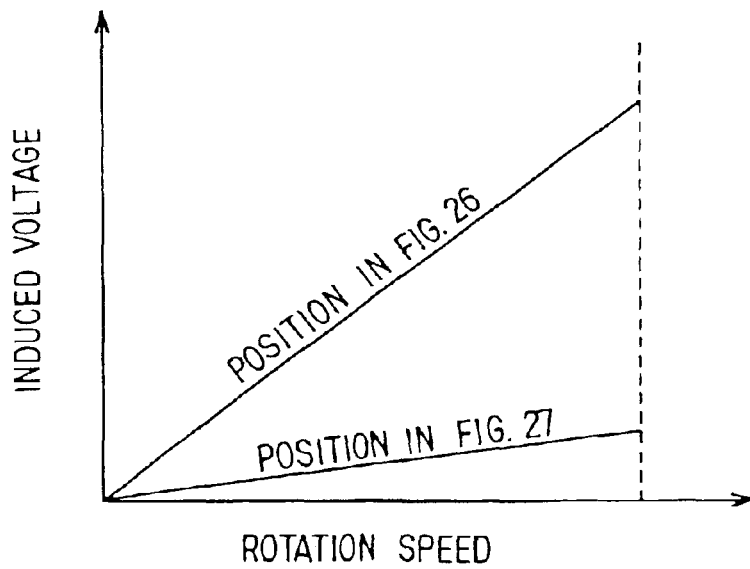

FIG. 29

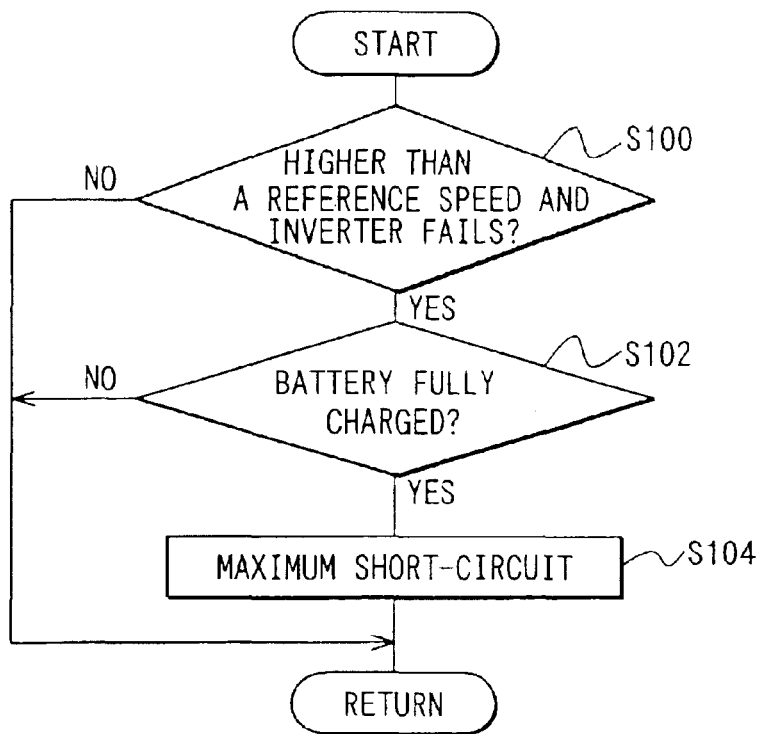

FIG. 30

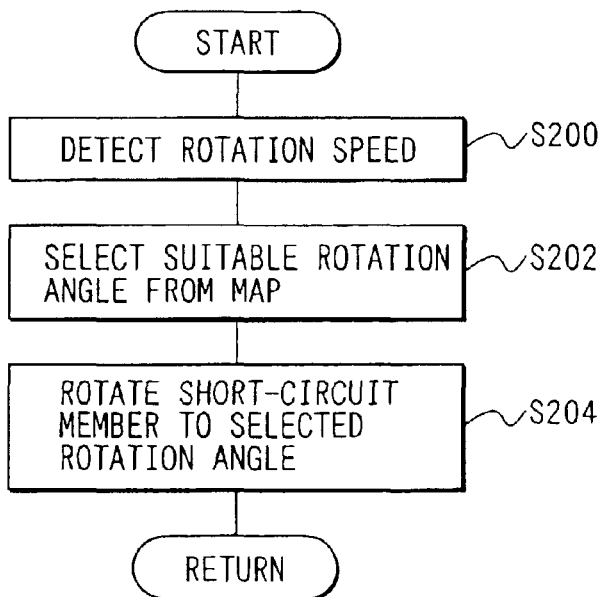



FIG. 32

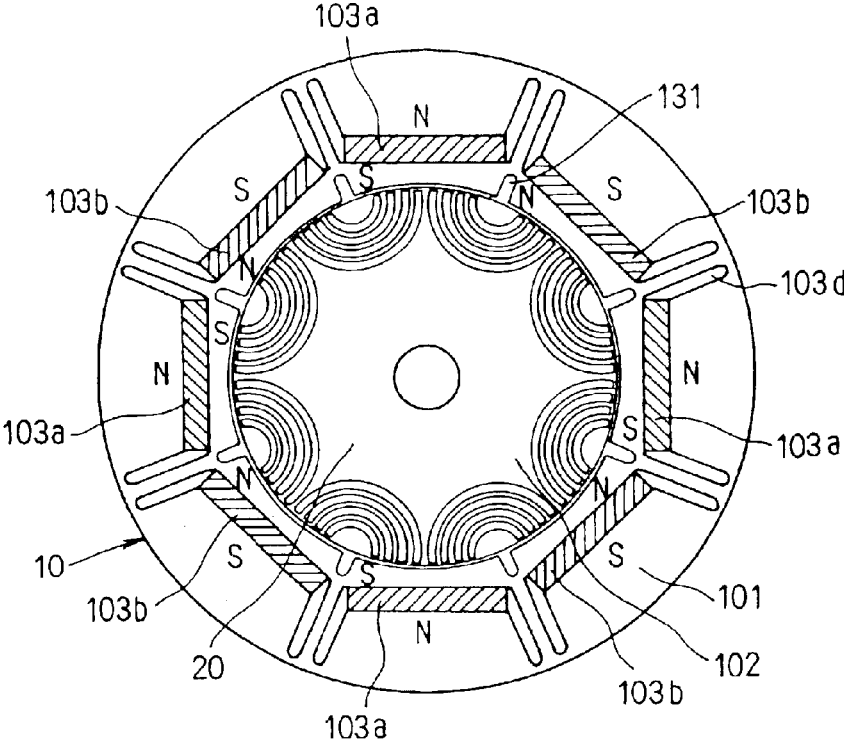

FIG. 33

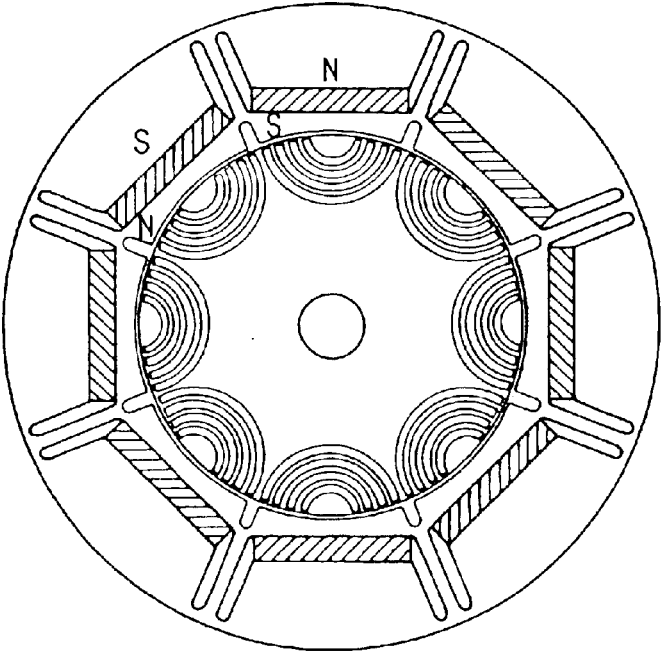

FIG. 34

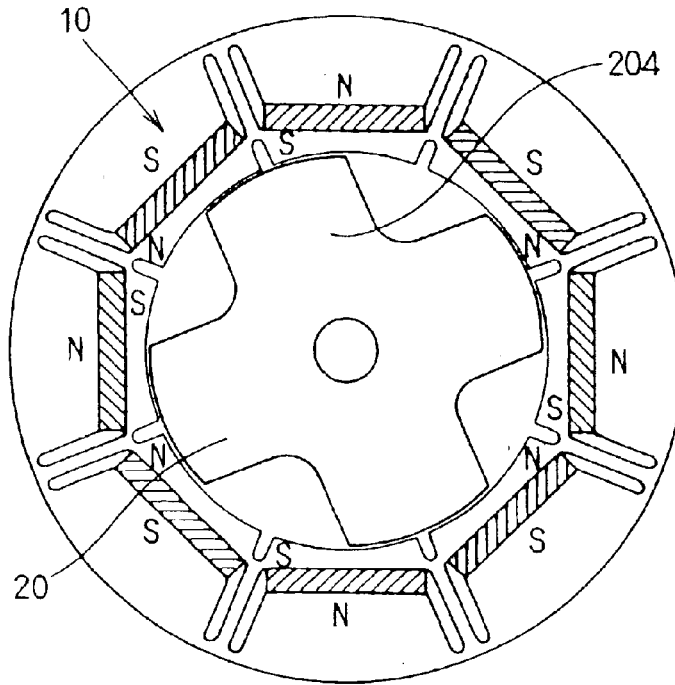

FIG. 35

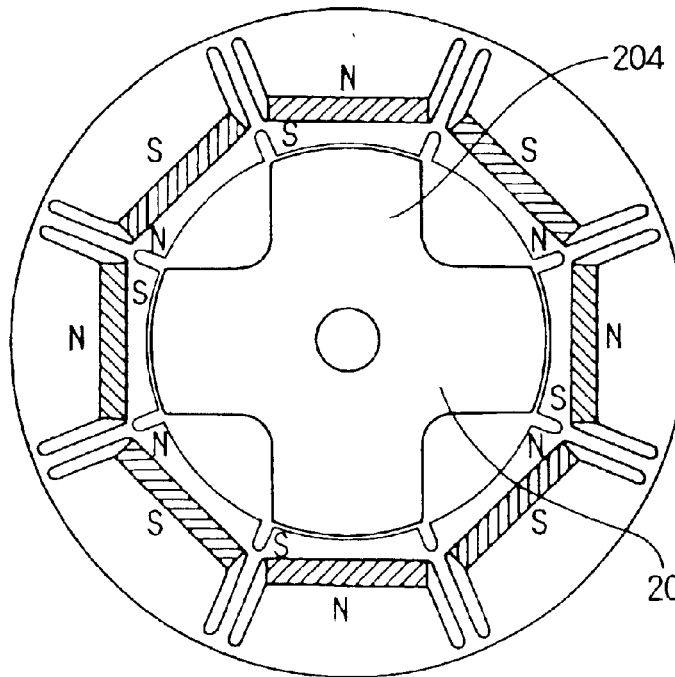

FIG. 36

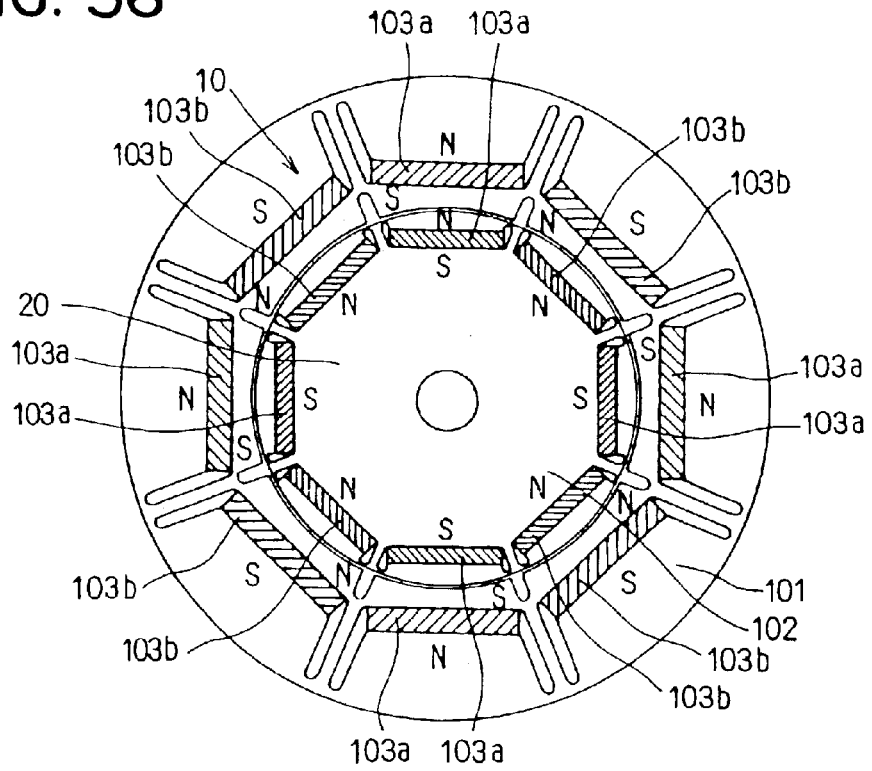
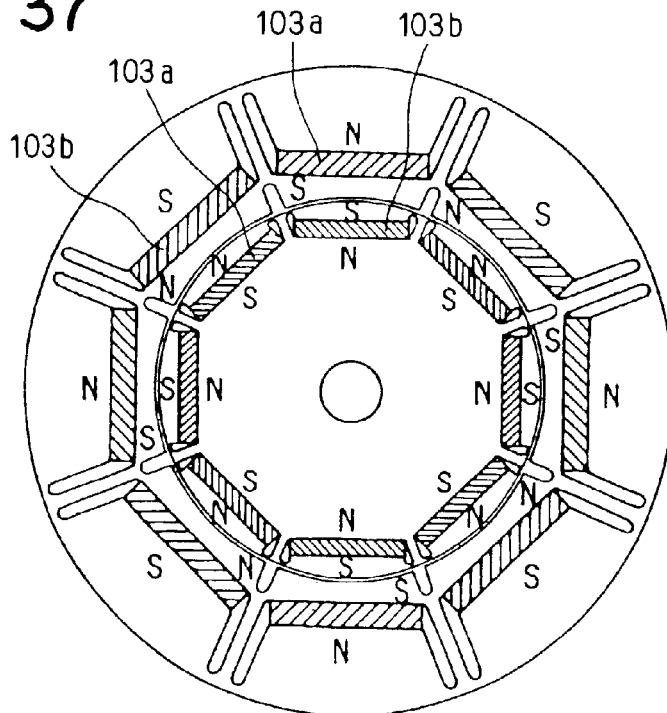

FIG. 37



1

## ROTARY ELECTRIC MACHINE FOR ELECTRIC VEHICLE

### CROSS REFERENCE TO RELATED APPLICATION

The present application is based on and claims priority from Japanese Patent Applications: Hei 11-292304, filed Oct. 14, 1999; 2000-132044, filed May 1, 2000; 2000-132423, filed May 1, 2000; and 2000-243914, filed Aug. 11, 2000, the contents of which are incorporated herein by reference.

### BACKGROUND OF THE INVENTION

#### 1. Field of the Invention

The present invention relates to a rotary electric machine to be mounted in an electric vehicle.

#### 2. Description of the Related Art

A synchronous electric rotary machine has been adopted to an electric vehicle or a hybrid vehicle because of its high efficiency and high durability. Such a rotary electric machine, which is known as a brush-less DC motor, preferably employs a permanent-magnet-type rotor because of its simple structure.

The output torque of a synchronous machine is proportional to a product of an amount of the armature current of the motor and a magnetic flux density of the magnetic field formed by permanent magnets. The output torque changes in a sinusoidal curve as a phase angle between the direction of the armature current and the direction of the magnetic field changes.

However, in such a synchronous machine used for a vehicle driving motor, if an A-D converter circuit connected between the armature coil and a battery fails to control the terminal voltage of the armature coil, the phase of armature current can not be controlled. Accordingly, the rotation speed of the permanent-magnet-type rotor becomes so high, that a very high output voltage is generated at the armature coil. This requires a smoothing capacitor and other circuits of a control circuit between the armature coil and the battery to provide means for protecting them from such a high voltage. This increases the size and cost of the smoothing capacitor and other circuits.

### SUMMARY OF THE INVENTION

A main object of the invention is to provide an improved rotary electric machine for driving a vehicle that provide an increased torque without requiring a smoothing capacitor and other circuit to provide means for protecting the circuit elements from a very high voltage.

Another object of the invention is to provide a rotary electric machine that includes a permanent-magnet-type rotor and a induction type rotor which does not require any permanent magnet, whereby a volume of the permanent magnets can be reduced. This prevents such an excessively high output voltage even if an A-D converter circuit fails to control the phase current of the armature winding.

According to a feature of the invention, a rotary electric machine includes a stator core having a plurality of slots disposed equally at an inner periphery, an armature winding disposed in the plurality of slots, and a rotor disposed inside the inner periphery of the stator. The rotor includes a first rotor portion and a second rotor portion disposed magnetically in parallel with the first rotor portion. The first rotor

2

portion has a plurality of permanent-magnet poles, and the second rotor portion has a plurality of salient induction poles. In the above structure, the plurality of permanent magnet poles and the plurality of salient induction poles are shifted from each other to provide a maximum combined output torque.

Preferably, the permanent-magnet poles and the salient induction poles are the same in number. This can combine the output torque of both the first and second rotor portions easily and effectively.

It is also preferable that the salient induction pole is disposed at an angle between 0° and 90°, more preferably between 45° and 75°, in electric angle in advance of the permanent-magnet pole.

According to another feature of the invention, each of the permanent-magnet poles has a permanent magnet inserted in an axially extending magnet hole of the first rotor portion.

According to another feature of the invention, the first rotor portion has as many axially extending arc-shaped slit-groups as the number of the permanent-magnet poles formed at the outer periphery thereof at equal intervals and a plurality of permanent magnets respectively inserted into the arc-shaped slit groups. Therefore, the first rotor portion and the second rotor portion can be formed in the same shape. Preferably, each of the permanent-magnet poles has a pair of permanent magnets inserted at opposite ends of one of the holes. Therefore, it is easy to insert permanent magnet into the holes.

According to another feature of the invention, the rotor includes a magnetic shield member disposed between the first and second rotor portions. Therefore, leakage magnetic flux can be reduced. This increases effective magnetic flux and, ultimately, the output torque.

Another object of the invention is to provide a simple and reliable rotary electric machine whose induced voltage can be controlled by a simple actuator.

According to another feature of the invention, a rotary electric machine includes a permanent-magnet-type rotor having a plurality of magnetic poles and a rotor shaft, a magnetically short-circuit mechanism, disposed near the rotor, for magnetically short-circuiting the magnetic poles. The short-circuiting mechanism includes a short-circuiting member and an actuator for moving the short-circuit member relative to the rotor. The short-circuit member may include a short-circuit plate and a member shaft disposed coaxial with the rotor shaft, and the actuator may be a planetary gear mechanism.

According to another feature of the invention, a rotary electric machine includes a stator having a cylindrical stator core and an armature winding, a cylindrical outer rotor portion disposed inside the stator core, an inner rotor portions disposed inside the outer rotor portion, and a relative angle control mechanism. The outer rotor portion has a plurality of permanent-magnet poles, and the relative angle control mechanism controls relative angular position between the outer and inner rotor portions. Preferably, the inner rotor has a plurality of salient induction poles.

### BRIEF DESCRIPTION OF THE DRAWINGS

Other objects, features and characteristics of the present invention as well as the functions of related parts of the present invention will become clear from a study of the following detailed description, the appended claims and the drawings. In the drawings:

FIG. 1 is a schematic diagram illustrating a rotary electric machine according to a first embodiment of the invention;

3

FIG. 2 is a schematic cross-sectional plan view of a first rotor portion of the rotary electric machine according to the first embodiment;

FIG. 3 is a schematic cross-sectional plan view of a second rotor portion of the rotary electric machine according to the first embodiment;

FIG. 4 is a graph showing characteristic curves of torque relative to phase-angles of the rotary electric machine according to the first embodiment;

FIG. 5 is a schematic cross-sectional plan view of a first rotor portion of the rotary electric machine according to a second embodiment of the invention;

FIG. 6 is a schematic cross-sectional plan view of a second rotor portion of the rotary electric machine according to the second embodiment;

FIG. 7 is a graph showing characteristic curves of torque relative to phase-angles of the rotary electric machine according to the second embodiment;

FIG. 8 is a circuit diagram of a control system for controlling the rotary electric machine according to the first and second embodiment mounted in a vehicle;

FIG. 9 is a schematic cross-sectional side view of a rotary electric machine according to a third embodiment of the invention;

FIG. 10 is a schematic cross sectional front view of a first rotor portion shown in FIG. 9 cut along line 10—10;

FIG. 11 is a schematic cross sectional front view of a second rotor portion shown in FIG. 9 cut along line 11—11;

FIG. 12 is a graph showing characteristic curves of torque relative to phase-angles of the rotary electric machine according to the third embodiment;

FIG. 13 is a graph showing characteristic curves of torque relative to phase-angles of the rotary electric machine according to the third embodiment;

FIG. 14 is a graph showing characteristic curves of torque relative to phase-angles of the rotary electric machine according to the third embodiment;

FIG. 15 is a fragmentary schematic cross-sectional side view of a rotary electric machine according to a fourth embodiment of the invention;

FIG. 16 is a fragmentary cross-sectional front view of the portion shown in FIG. 15 cut along line 16—16.

FIG. 17 is a circuit diagram of a vehicle driving system for controlling the rotary electric machine according to the fourth embodiment;

FIG. 18 is schematic longitudinal cross-sectional view of a rotary electric machine according to a fifth embodiment of the invention;

FIG. 19 is a graph showing characteristic curves of torque relative to phase-angles of the rotary electric machine according to the fifth embodiment;

FIG. 20 is a graph showing characteristic curves of torque relative to phase-angles of the rotary electric machine according to the fifth embodiment;

FIG. 21 is a graph showing characteristic curves of torque relative to phase-angles of the rotary electric machine according to the fifth embodiment;

FIG. 22 is a graph showing characteristic curves of torque relative to phase-angles of the rotary electric machine according to the fifth embodiment;

FIG. 23 is a fragmentary cross-sectional front view of a rotary electric machine according to a sixth embodiment of the invention;

4

FIG. 24 is a schematic longitudinal cross-sectional view of a rotary electric machine according to a seventh embodiment;

FIG. 25 is a schematic cross-sectional plan view of a rotor portion of the rotary electric machine according to the seventh embodiment;

FIG. 26 is a schematic cross-sectional plan view of a rotor portion of the rotary electric machine according to the seventh embodiment;

FIG. 27 is a schematic cross-sectional plan view of a rotor portion of the rotary electric machine according to the seventh embodiment;

FIG. 28 is a graph showing induced voltages of the rotary electric machine according to the seventh embodiment;

FIG. 29 is a flow diagram of a drive control system for controlling the rotary electric machine according to the seventh embodiment mounted in a vehicle;

FIG. 30 is a flow diagram of a drive control system for controlling the rotary electric machine according to the seventh embodiment mounted in a vehicle;

FIG. 31 is a schematic longitudinal cross-sectional view of a rotary electric machine according to an eighth embodiment of the invention;

FIG. 32 is a schematic cross-sectional plan view of a rotor portion of the rotary electric machine according to the eighth embodiment;

FIG. 33 is a schematic cross-sectional plan view of two rotor portions of the rotary electric machine according to the eighth embodiment;

FIG. 34 is a schematic cross-sectional plan view of a variation of a rotor portion of the rotary electric machine according to the eighth embodiment;

FIG. 35 is a schematic cross-sectional plan view of the variation of a rotor portion of the rotary electric machine according to the eighth embodiment;

FIG. 36 is a schematic cross-sectional plan view of a variation of a rotor portion of the rotary electric machine according to the eighth embodiment; and

FIG. 37 is a schematic cross-sectional plan view of the variation of a rotor portion of the rotary electric machine according to the eighth embodiment.

#### DETAILED DESCRIPTION OF THE PREFERRED EMBODIMENTS

A rotary electric machine according to a first embodiment of the invention is described with reference to FIGS. 1–4.

The rotary electric machine is driven by an engine of a hybrid vehicle to generate electric power and is also powered by a battery to start the engine. The rotary electric machine has stator core 201 with armature winding 202 wound thereon and rotor 100 disposed inside stator core 201. Stator core 201 is formed of laminated iron sheets and has a plurality of slots, which respectively accommodate in-slot portions of armature winding 202 as generally indicated by broken lines, is fixed to a housing (not shown).

Rotor 100 has shaft 108, which is supported by the housing via bearings 401 and 402. Rotor 100 is comprised of first rotor portion 10 and second rotor portion 20. First rotor portion 10 is comprised of a pair of first cores 101, and second rotor portion 20 is comprised of second core 102. Both first and second cores 101 and 102 are formed of laminated iron sheets. The pair of first cores 101 forms a permanent-magnet-type rotor portion, and second core forms a salient-induction-pole-type rotor portion. The pair

of first cores **101** and second core **102** are respectively fixed to shaft **108** by means of key **107**. Second core **102** is sandwiched by the pair of first cores **101**, which is sandwiched by a pair of plates **105**, in the axial direction of shaft **108**. The pair of plates **105** is also fixed to shaft **108**. Nonmagnetic plates **106** is inserted between each of the pair of first cores **101** and second core **102** to magnetically insulate first core **101** and second core **102** from each other.

As shown in FIG. 2, alternately polarized eight permanent magnets **103a** and **103b** are respectively inserted into eight holes **111** formed at the outer periphery of first core **101** at equal intervals. However, permanent magnets **103** can be exposed outside. Each permanent magnet **103** is magnetized in the thickness direction thereof (the radial direction of the rotor) so as to alternately provide N-pole and S-pole in the circumferential direction.

First core **101** has center hole **112**, to which shaft **108** and key **107** are fitted. The circumferential center of the keyhole of key **107** is positioned at the same angular position as the circumferential center of magnet hole **111**.

Second core **102** has eight slit groups **110** formed in the circumferential direction thereof at equal interval. There are eight boundary center portions in second core **102**, which respectively form magnetic salient poles.

Each slit group **110** has four arc-shaped slits **110a**, **110b**, **110c**, and **110d**. Second core **102** has center hole **109**, to which the above-described shaft **108** and key **107** are also fitted. The keyhole of key **107** is positioned so that the boundary center portion between two adjacent slit groups **110** is shifted counterclockwise (in the rotating direction) from the circumferential center of the keyhole of key **107** by  $11.25^\circ$  (that corresponds to  $45^\circ$  in electric angle). That is, the salient induction pole of second core **102** is disposed in advance of the permanent magnet pole of first core **101** by  $45^\circ$  in electric angle. This angle can be changed to any angle between  $0^\circ$  and  $90^\circ$ . A higher torque can be provided at a higher speed if such angle is selected between  $45^\circ$  and  $90^\circ$ .

Armature winding **202** is a three-phase winding, which has in-slot portions inserted in a predetermined number of slots of stator core **201**. The predetermined number of slots is formed at the inner periphery of stator core **201** at equal intervals.

In first core **101**, there is a plurality of magnetic circuits. For example, a magnetic flux comes out from N-poled permanent magnet **103a**, passes through stator **200** and goes back to S-poled permanent magnet **103b** in one of the magnetic circuit. When three-phase alternating current is supplied to armature winding **202**, a rotating magnetic field is formed.

Generally, a magnet torque generated by permanent magnets **103a**, **103b** and the rotating magnetic field of the armature winding is proportional to  $\sin \theta$ , if  $\theta$  represents the phase angle or the difference in phase between the direction of the magnetic flux of the permanent magnet and the direction of the rotating magnetic field. Therefore, a maximum torque is generated by first core **101** when the phase angle is  $90^\circ$ , as shown in FIG. 4. In FIG. 4, the phase angle is zero when the circumferential center of N-pole magnet **103a** and the direction of the rotating magnetic field agree with each other. If the rotating magnetic field rotates in the rotating direction of the rotor, the phase angle increases.

A reluctance torque is generated by second core **102** and the rotating magnetic field. A maximum reluctance torque is generated by second core **102** when the direction of the rotating magnetic field agree, or makes a right angle, with the middle portion between the circumferential center of the

magnetic salient pole and the circumferential center of the slit group. As shown in FIG. 4, the maximum torque generated by first core **101** and the maximum torque generated by second core **102** are properly combined.

A rotary electric machine according to a second embodiment of the invention is described with reference to FIGS. 5-8.

Rotor **1** of the rotary electric machine according to the second embodiment is comprised of a pair of first cores **121** on the opposite ends of rotor **1** and second core **122** between the pair of first cores **121**. That is, the pair of first cores **101** of the first embodiment is substituted by the pair of first core **121**, and second core **102** is substituted by second core **122**. Second core **122** is the same in shape as second core **102** of the first embodiment. First core **121** has the same shape as second core **102** except for permanent magnets **123a-123d** inserted in respective four slits of each slit group, as shown in FIG. 5. Each of permanent magnets **123a-123d** is polarized in the thickness direction (radial direction of the rotor) to provide N or S pole alternately in the circumferential direction.

Second core **122** is fixed to first core **122** so that the circumferential center of the salient pole portion of second core **122** advances  $18.75^\circ$  in mechanical angle or  $75^\circ$  in electric angle from the magnetic flux of the permanent magnet pole.

As shown in FIG. 7, the torque generated by first core **121** and the torque generated by second core **122** are combined properly to provide maximum torque.

The rotary electric machine according to the first or second embodiment of the invention is mounted in a hybrid vehicle to drive the same, as shown in FIG. 8. A vehicle driving system shown in FIG. 8 includes rotary electric machine **300**, battery **301**, inverter **302**, angular position sensor **303**, controller **304**, and smoothing capacitor **305**. Inverter **302** controls transfer of an electric power between rotary electric machine **300** and battery **301**. Sensor **303** detects the rotor angular position. Controller **304** controls inverter **302** according to the angular position of the rotor and a torque command signal sent from outside. Smoothing capacitor **305** is connected in parallel with battery **301**.

Even if controller **304** fails and inverter **302** can not control the transfer of an electric power properly with the battery being fully charged, the output voltage of rotary electric machine **300** is sufficiently small because of small volume of the permanent magnets. As a result, means for protecting inverter **302** and smoothing capacity **305** from a very high voltage is not necessary.

A rotary electric machine according to a third embodiment of the invention is described with reference to FIGS. 9-14.

In the meantime, the same reference numeral as that used in the previous embodiments in the figures presented below represents the same or substantially the same part or component as described above.

The rotary electric machine according to the third embodiment is comprised of rotor **1**, stator **2**, motor housing **3**, gear housing **601**, and input-output shaft (or planetary carrier) **501**.

Stator **2** is comprised of first stator core **2011**, second stator core **2012**, non-magnetic plate **2013** disposed between first stator core **2011** and second stator core **2012**, and armature winding **202**, which are held in motor housing **3**.

Rotor **1** is disposed inside stator **2** and supported by motor housing **3** via bearings **401** and **402**. Rotor **1** is comprised of first rotor portion **10** and second rotor portion **20**.

As shown in FIG. 10, first rotor portion 10 is comprised of hollow shaft 1081 and first rotor core 101 made of laminated iron sheets, and eight permanent magnets 103a and 103b, which are respectively inserted into eight axially extending magnet holes 103c of first rotor core 101. Eight magnet holes 103c are formed at the peripheral portion of first rotor core 101, and N-poled permanent magnets 103a and, S-poled permanent magnets 103b are alternately inserted into magnet holes 103c.

As shown in FIG. 11, second rotor portion 20 is comprised of shaft 1082 and second rotor core 102 made-of laminated iron sheets, and eight permanent magnets 103a and 103b, which are respectively inserted into eight axially extending magnet holes 103c of second rotor core 102. Eight magnet holes 103c are formed at the peripheral portion of second rotor core 102, and N-poled permanent magnets 103a and S-poled permanent magnets 103b are alternately inserted into magnet holes 103c.

The rear portion (right in FIG. 9) of shaft 1082 is supported by motor housing 3 via bearing 404. The front portion of shaft 1082 is supported by hollow shaft 1081 via bearings 403 so as to extend through the hollow portion of hollow shaft 1081 into the inside of gear housing 601.

The front portion of shaft 1081 is supported by motor housing via bearing 401, so that both shafts 1081 and 1082 are disposed to be coaxial with each other. Gear housing 601 accommodates a planetary gear unit.

A pair of sun gears 502 and 503 is respectively fixed to the front ends of shafts 1081 and 1082. Sun gear 502 links ring gear 506 via planetary gear 504, and sun gear 503 links with ring gear 507 via planetary gear 505. Planetary gear 504 and 505 are respectively supported, via bearings 509 and 510, by common support-shaft 508. Shaft 508 is fixed to output-input shaft 501 at its rear flange portion. Output-input shaft 501 is rotatably supported by gear housing 601 via bearing 405.

Ring gear 506 is fixed to the inner periphery of gear housing 601, and ring gear 507 is rotatably supported by the inner periphery of gear housing 601 via bearing 511. The front side of ring gear 507 has a gear portion 512 in mesh with worm gear 701 formed at an output shaft of rotary actuator 700 disposed in gear housing 601. Gear housing 601 contains lubrication oil therein, and oil-seal members 901 and 902 are respectively fitted to spaces between gear housing 601 and output shaft (planetary carrier) 501 and between gear housing 601 and shaft 1081.

Rotation sensors 801 and 802 are respectively fixed to front and rear portions of motor housing 3 to detect angular position of first and second rotor portions 10 and 20.

The torque of first rotor portion 10 and the torque of second rotor portion 20 are transmitted, via sun gears 502, 503, planetary gears 504 and 505, to output-input shaft 501, which combines the torque of the first and second rotor portions 10 and 20. When worm gear 701 is rotated to rotate ring gear 507, sun gear 503 rotates first rotor portion 10 relative to second rotor portion 20. Therefore, the torque of first rotor portion 10 is changed so that the composite torque can be changed.

As shown in FIG. 12, when the magnetic poles of first rotor portion 10 and the magnetic poles of second rotor portion 20 are disposed at the same angular positions with the phase difference between two being zero, the torque generated by both first and second rotor portions is the same and a maximum composite torque can be obtained at the phase angle of 90°. The composite torque is provided at the output-input shaft 501 that is transmitted from first rotor portion 10 and second rotor portion 20 via the planetary gear unit.

First rotor portion 10 can be rotated relative to second rotor portion 20 by ring gear 507 in the direction opposite the rotating direction, for example in a range between 0°–180° in electric angle or 0°–45° in mechanical angle. As shown in FIG. 13, when the magnetic poles of first rotor portion 10 and the magnetic poles of second rotor portion 20 are shifted by 90° in electric angle from each other, the torque generated by both first and second rotor portions is different in phase, and a reduced composite torque can be obtained. In this case, a reduced maximum composite torque can be obtained at the phase angle  $\theta$  being 135°. This also reduces the output voltage when the rotary electric machine is used as a generator.

As shown in FIG. 14, the composite torque becomes zero if the phase difference between first and second rotor portions 10 and 20 is 180° in electric angle. This also reduces the output voltage to zero.

Thus, a ring gear of one of two planetary-gear-type speed reduction mechanisms is changed to control composite magnetic flux that is interlinked with the armature winding.

One of rotation sensors 801 and 802 can be omitted if the angular position of rotary actuator 700 or ring gear 507 can be detected.

As long as the rotary electric machine normally operates as a motor or a generator, the phase difference between the two rotor portions should be controlled at a position where a maximum value of positive or negative composite torque equals to a required torque. It would be possible to control the phase difference between first and second rotor portions to a suitable phase difference while the rotary electric machine operates normally. If the phase angle of the second rotor portion, which is not controllable, is set 90° to generate maximum electric power or set 270° to generate maximum torque, it is easy to provide a suitable electric power or torque by mechanically controlling the phase angle of the first rotor portion.

A rotary electric machine according to a fourth embodiment of the invention is described with reference to FIGS. 15 and 16.

Stator 200 is comprised of laminated stator core 201 and stator winding 202, and is fixed to motor housing 3 by a plurality of supporting rods 33. Outer rotor portion 10 is disposed around the outer surface of stator 200 to face the same via an air gap, and inner rotor portion 20 is disposed inside the inner surface of stator 200 to face the same via an air gap.

Outer rotor portion 10 is comprised of outer rotor core 101 formed of laminated iron sheets, hollow or cup-shaped shaft 1082, and permanent magnets 103a and 103b respectively inserted in magnet holes 103c. Permanent magnets 103a and 103b are also magnetized in the thickness direction thereof to provide different polarities, so that circumferentially alternating magnetic fields can be provided.

Inner rotor portion 20 is comprised of inner rotor core 102 formed of laminated iron sheets, hollow shaft 1081, and permanent magnets 103a and 103b respectively inserted in magnet holes 103c. Permanent magnets 103a and 103b are respectively magnetized in the thickness direction thereof to provide different polarities, so that circumferentially alternating magnetic fields can be provided.

Hollow or cup-shaped shaft 1081 is rotatably supported by shaft 1082 via bearings 403 and 404, and hollow shaft 1082 is rotatably supported by clutch plate 2000 via bearings 401 and 402.

Hollow shaft 1081 has a cylindrical inner space, in which sun gears 502 and 503 are disposed closely to each other.

Sun gear **502** is connected to ring gear **506** via planetary gear **504**, and sun gear **503** is connected to ring gear **507** via planetary gear **505**. Planetary gears **54** and **55** are rotatably supported by common shaft **508**, which is fixed to planetary carrier **501**, which is an input-output shaft. Planetary carrier **501** is fixed to engine crankshaft **1000** and clutch plate **2000**.

Ring gear **506** is fixed to housing **3**, and ring gear **507** is rotatably supported by housing **3** via bearing **509**. Ring gear **507** has gear **702** that is in mesh with a gear of output linkage **701** of actuator **700**.

Rotation sensors **801** and **802** respectively detect the positions of inner rotor portion **20** and outer rotor portion **10**.

The operation of this rotary electric machine is substantially the same as the rotary machine according to the third embodiment of the invention, except that the composite torque becomes zero as shown in FIG. **14** when the phase difference is  $0^\circ$  instead of  $180^\circ$ .

The rotary electric machine according to the fourth embodiment of the invention is mounted in vehicle driving system of a hybrid vehicle as shown in FIG. **17**. The vehicle driving system includes synchronous motor **300**, battery **301**, inverter **302**, angular position sensors **801** and **802**, rotary actuator **700**, controller **304**, and smoothing capacitor **305**. Inverter **302** controls transfer of an electric power between rotary electric machine **300** and battery **301**. Angular position sensors **801** and **802** detect the angular positions of the first and second rotor portions. Controller **304** controls inverter **302** according to the angular positions of the first and second rotor portions and a torque command signal sent from outside. Smoothing capacitor **305** is connected in parallel with battery **301**.

If controller **304** fails and inverter **302** can not control the transfer of an electric power properly with the battery being fully charged, the phase difference between the first and second rotor portions are controlled as described above so that the output voltage of rotary electric machine **300** can be controlled at a suitable level. As a result, inverter **302** and smoothing capacity **305** can be protected effectively.

As a variation of the above embodiment, one of the first and second permanent-magnet-type rotor portions can be substituted by a salient-induction-pole-type rotor that is described above.

A rotary electric machine according to a fifth embodiment of the invention is described with reference to FIGS. **18–20**.

Rotor **100** is comprised of permanent-magnet-type first rotor portion **10** and salient induction pole-type second rotor portion **20**. Second rotor portion **20** is substantially the same in structure as the first embodiment shown in FIG. **3**. Preferably, the outside diameter of the second rotor portion **20** is larger than first rotor portion **10**. In other words, the air gap between stator **200** and second rotor portion is smaller than the air gap between stator **200** and first rotor portion. **10**. Other parts and components are substantially the same as the rotary electric machine shown in FIG. **9**.

If ring gear **507** is not rotated, a composite torque can be obtained as shown in FIG. **19**.

If this rotary electric machine is operated as a motor at a low speed, ring gear **507** is rotated in the direction opposite the rotor's rotating direction to advance second rotor portion **20** to first rotor portion **10** by  $11.25^\circ$  ( $45^\circ$  in electric angle). Then, a maximum torque can be obtained at phase angle  $90^\circ$ , as shown in FIG. **4**.

If this rotary electric machine is operated as a motor at a high speed, it is necessary to rotate the ring gear so that the rotary electric machine can operate at a phase angle between

$90^\circ$  and  $180^\circ$ , in order to reduce the permanent-magnet flux. A large composite torque can be provided if the peak of the torque generated by second rotor portion **20** comes at a phase angle between  $90^\circ$  and  $180^\circ$ , as shown in FIG. **20**.

If this rotary machine is operated as a generator at a low speed, ring gear **507** is rotated in the same direction as the rotor's rotating direction to retard second rotor portion **20** from first rotor portion **110** by  $11.25^\circ$  ( $45^\circ$  in electric angle). Consequently, the composite torque becomes maximum at the phase angle of  $270^\circ$ , as shown in FIG. **21**.

If this rotary electric machine is operated as a generator at a high speed, it is generally operated at a phase angle between  $180^\circ$  and  $270^\circ$ , as shown in FIG. **22**. If the torque peak of second rotor portion **20** comes at a phase angle between  $180^\circ$  and  $270^\circ$ , a maximum composite torque can be provided.

A rotary electric machine according to a sixth embodiment of the invention is described with reference to FIG. **23**.

Permanent-magnet-type second rotor portion **20** can be substituted by a salient induction pole-type rotor portion as described above. Generally, the salient-induction-pole-type rotor portion is suitable to such second rotor portion disposed radially outer side of the first rotor portion, because the former is stronger against a centrifugal force than the permanent-magnet-type rotor portion.

Salient-induction-pole-type rotor portion **20** is comprised of stator core **201** made of laminated iron sheets and hollow shaft **1082**. Second rotor core **201** has a plurality of groups of arc-shaped slits **110b**, **110c** and **110d** with the convex portion being radially outside. The plurality of groups of slits **110b**, **110c** and **110d** are formed in the circumferential direction of second rotor core **102** at equal intervals.

Because second rotor portion **20** does not have a plurality of permanent magnets, the output voltage will not exceed a maximum withstand voltage of control circuits even if the rotation speed of the rotary electric machine becomes maximum.

A rotary electric machine according to a seventh embodiment is described with reference to FIGS. **24–32**.

The rotary electric machine according to the seventh embodiment is comprised of permanent-magnet-type rotor **1**, stator **2**, motor housing **3**, gear housing **4**, output-input shaft **501**, magnetic short-circuit member **6**, gear housing **601** and a planetary gear mechanism accommodated in gear housing.

Permanent-magnet-type rotor **1** is comprised of hollow shaft **1081**, rotor core **101** made of laminated iron sheets core, eight permanent magnets **103a**, and **103b**, and eight magnetic pins **14**. Eight permanent magnets **103a** and **103b** are alternately polarized in opposite radial directions and buried in eight magnet holes **103c** that are formed in rotor core **101** at equal angular intervals. Each magnet hole **103c** has circumferentially extending main portion and a pair of radial-outwardly extending end portions. Eight magnetic pins **104**, which are made of soft magnetic material, are fitted in eight pin-holes **104c** formed in rotor core **101** at the radially outer side of magnet holes **103c** at equal angular intervals. The right ends of magnetic pins **104** project right from the right end of rotor core **101**. Each pin-hole **104c** may be connected to one of magnet holes **103c**.

Short-circuit member **6** is comprised of shaft **61** and short-circuit plate **62** fixed to shaft **61**. Short-circuit plate **62** is a disk plate made of a soft magnetic material and is disposed near the right ends of magnetic pins **104**. As shown in FIG. **26**, short-circuit plate **62** has four salient portions **62a**. Shaft **61** is inserted in rotor shaft **1081**.

## 11

Other portions are substantially the same as the rotary machine according to the third embodiment shown in FIG. 9.

If ring gear 507 is not rotated, short-circuit plate is disposed as shown in FIG. 26. Accordingly, a minimum short-circuit path is formed between neighboring poles so that a maximum effective magnetic flux is supplied to stator winding 202. On the other hand, if ring gear 507 is rotated, short-circuit plate is located at positions shown in FIG. 27. Accordingly, a maximum short-circuit path including the right end portions of magnetic pins 104 is formed between neighboring poles so that a minimum effective magnetic flux is supplied to stator winding 202.

For example, if this rotary electric machine is operated as a motor at a low speed, ring gear 507 is not rotated so that a maximum torque can be obtained. If this rotary electric machine is operated as a motor at a high speed, short-circuit plate 62 is rotated to the position shown in FIG. 27 to reduce the permanent-magnet flux. If this rotary machine is operated as a generator at a low speed, short-circuit plate is returned to the original position shown in FIG. 26. Consequently, the torque becomes maximum. If this rotary electric machine is operated as a generator at a high speed, short-circuit plate 62 is rotated to the position shown in FIG. 27 to prevent stator winding 202 from generating an abnormally high voltage.

The rotary electric machine according to the seventh embodiment is mounted in a vehicle driving control system of a hybrid vehicle, as shown in FIG. 17. If the rotary electric machine according to the seventh embodiment is used as a generator, it may be controlled as follows, as shown in FIG. 31.

After the driving control system starts, whether or not the rotary electric machine operates at a high speed and inverter 302 fails is examined.

If the result is YES, whether or not battery 301 is fully charged is examined at step S102. On the other hand, if the result of step S100 is NO, step S100 is repeated.

If the result of step S102 is YES, rotary actuator 700 rotates short-circuit plate 62 to the maximum short-circuit position shown in FIG. 27 at step S104. Accordingly, effective magnetic flux decreases, so that the voltage induced in the stator winding can be controlled within an allowable level, as shown in FIG. 28. On the other hand, if the result of step S102 is NO, step S100 is also repeated.

Instead of examining the operation failure described above, it is possible to control short-circuit plate 62 according to the rotation speed, as shown in FIG. 30.

At step S200, the rotation speed is detected. Subsequently at step S202, rotation angle of short-circuit plate 62 that corresponds to the rotation speed is selected from a map. At step S204, rotary actuator 700 rotates short-circuit plate 62 to the selected rotation angle, so that the output voltage can be controlled within an allowable level.

A rotary electric machine according to an eighth embodiment is described with reference to FIGS. 31–33.

The rotary electric machine according to the eighth embodiment is comprised of rotor 1, stator 2, motor housing 3, gear housing 4, output-input shaft 501, gear housing 601 and a planetary gear mechanism accommodated in gear housing 4. Rotor 1 is comprised of hollow shaft 1081, outer rotor portion 10, inner rotor portion 20, eight permanent magnets 103a, and 103b, and flange member 106. Outer and inner rotor portions 100 and 200 are respectively made of cylindrical rotor cores 101 and 102 of laminated iron sheets.

## 12

Eight permanent magnets 103a and 103b are alternately polarized in opposite radial directions and buried in eight magnet holes 103c that are formed in rotor core 101 at equal angular intervals. Each magnet hole 103c has circumferentially extending main portion and a pair of radial-outwardly extending end portions. Eight radial grooves 131 are also formed at equal angles in the inner periphery of rotor core 101 of outer rotor portion 10, so as to reduce leakage magnetic fluxes. Inner rotor portion 20 is a salient-induction-pole-type rotor as described above.

Flange member 106 is carried by shaft 1082, which is supported in the same manner as described above.

Other portions are substantially the same as those having the same reference numeral described above.

When outer rotor portion 10 rotates in synchronism with the rotating magnetic field of armature winding 202, inner rotor portion 20 is rotated by outer rotor portion 10 via shaft 1081, sun gear 502 planetary gear 504, planetary gear 505, sun gear 503, and shaft 1082.

Therefore, the effective magnetic flux supplied to armature winding 202 can be changed in the same manner as described above.

If warm gear 701 does not rotate ring gear 507, outer rotor portion 10 and inner rotor portion 20 are located as shown in FIG. 32. Accordingly, a minimum short-circuit path is formed between neighboring poles so that a maximum effective magnetic flux is supplied to stator winding 202.

On the other hand, if warm gear 701 rotates ring gear 507, sun gear 503 rotates inner rotor portion 20 relative to outer rotor portion 10, as shown in FIG. 33. Accordingly, a maximum short-circuit path is formed between neighboring poles so that a minimum effective magnetic flux is supplied to stator winding 202.

The rotary electric machine according to the eighth embodiment is mounted in a vehicle driving control system of a hybrid vehicle and controlled in the same manner as described above.

The above-described structure of inner rotor portion 20 can be substituted by a structure shown in FIGS. 34 and 35. This inner rotor portion 20 has four salient core members 204.

If warm gear 701 does not rotate ring gear 507, outer rotor portion 10 and inner rotor portion 20 are disposed as shown in FIG. 34. Accordingly, a maximum short-circuit path is formed between neighboring poles so that a minimum effective magnetic flux is supplied to stator winding 202.

On the other hand, if warm gear 701 rotates ring gear 507, sun gear 503 rotates inner rotor portion 20 relative to outer rotor portion 10, as shown in FIG. 35, and a maximum effective magnetic flux is supplied to stator winding 202.

The above-described structure of inner rotor portion 20 can be also substituted by a structure shown in FIGS. 36 and 37. This inner rotor portion 20 has eight radially-and alternately-polarized permanent magnets 103a, 103b, which are buried in magnet holes formed in rotor core 102 at equal circumferential intervals.

If warm gear 701 does not rotate ring gear 507, outer rotor portion 10 and inner rotor portion 20 are disposed as shown in FIG. 36. Accordingly, permanent magnets 103a and 103b of both outer and inner rotor portions 10 and 20 overlap in the radial direction to strengthen the magnetic force. As a result a maximum effective magnetic flux is supplied to armature winding 202.

On the other hand, if warm gear 701 rotates ring gear 507, sun gear 503 rotates inner rotor portion 20 relative to outer

13

rotor portion **10**, as shown in FIG. **37**. Accordingly, permanent magnets **103a** and **103b** of both outer and inner rotor portions **10** and **20** overlap in the radial direction to offset the magnetic force each other. As a result, a minimum effective magnetic flux is supplied to armature winding **202**. Thus, the effective magnetic flux can be properly controlled.

In the foregoing description of the present invention, the invention has been disclosed with reference to specific embodiments thereof. It will, however, be evident that various modifications and changes may be made to the specific embodiments of the present invention without departing from the broader spirit and scope of the invention as set forth in the appended claims. Accordingly, the description of the present invention is to be regarded in an illustrative, rather than a restrictive, sense.

What is claimed is:

1. A rotary electric machine comprising:
  - a stator including a stator core having a plurality of slots formed equally in a circumferential direction at the inner periphery thereof and an armature winding having a plurality of in-slot portions respectively disposed in said slots; and
  - a permanent-magnet-type rotor having a plurality of magnetic poles and a rotor shaft;
  - a magnetically short-circuit mechanism, disposed near said rotor, for magnetically short-circuiting said magnetic poles.
2. The rotary electric machine as claimed in claim **1**, wherein
  - said short-circuit mechanism comprises a short-circuiting member and an actuator for moving said short-circuit member relative to said rotor.
3. The rotary electric machine as claimed in claim **2**, wherein

14

- said short-circuit member comprises a short-circuit plate and a member shaft disposed coaxial with said rotor shaft,
- said actuator comprises a planetary gear mechanism.
- 4. The rotary electric machine as claimed in claim **3**, said planetary gear mechanism comprises:
  - a pair of sun gears respectively fixed to said rotor shaft and said member shaft;
  - a pair of planetary gears respectively engaged with said pair of sun gears;
  - a pair of ring gears respectively engaged with said pair of planetary gears; and
  - a rotation mechanism for rotating one of said pair of ring gears.
- 5. The rotary electric machine as claimed in claim **2**, wherein
  - said actuator moves said short-circuit member to decrease an effective magnetic flux supplied to said armature winding if said rotor rotates at a speed higher than a preset level.
- 6. The rotary electric machine as claimed in claim **1**, wherein
  - said permanent-magnet-type rotor comprises a rotor core formed of a plurality of laminated iron sheets having a plurality of longitudinally extending magnet-holes and a plurality of longitudinally extending pin-holes and a plurality of pins inserted in said plurality of pin-holes, and
  - said plurality of permanent magnets are inserted into said magnet holes.

\* \* \* \* \*